

Screw list:

- Screw M5/35 – 4pcs – marked as
- Screw M5/45 – 12pcs – marked as
- Screw M5/50 – 2pcs – marked as
- Screw M5/60 – 2pcs – marked as
- Butterfly nut – 8pcs – marked as
- Standard nut – 12pcs – marked as
- Washer – 20pcs – marked as
- Screw M3/35 – 4pcs – marked as
- Screw M3/12 – 4pcs – marked as

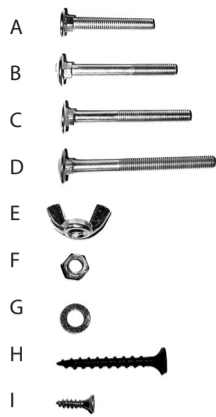
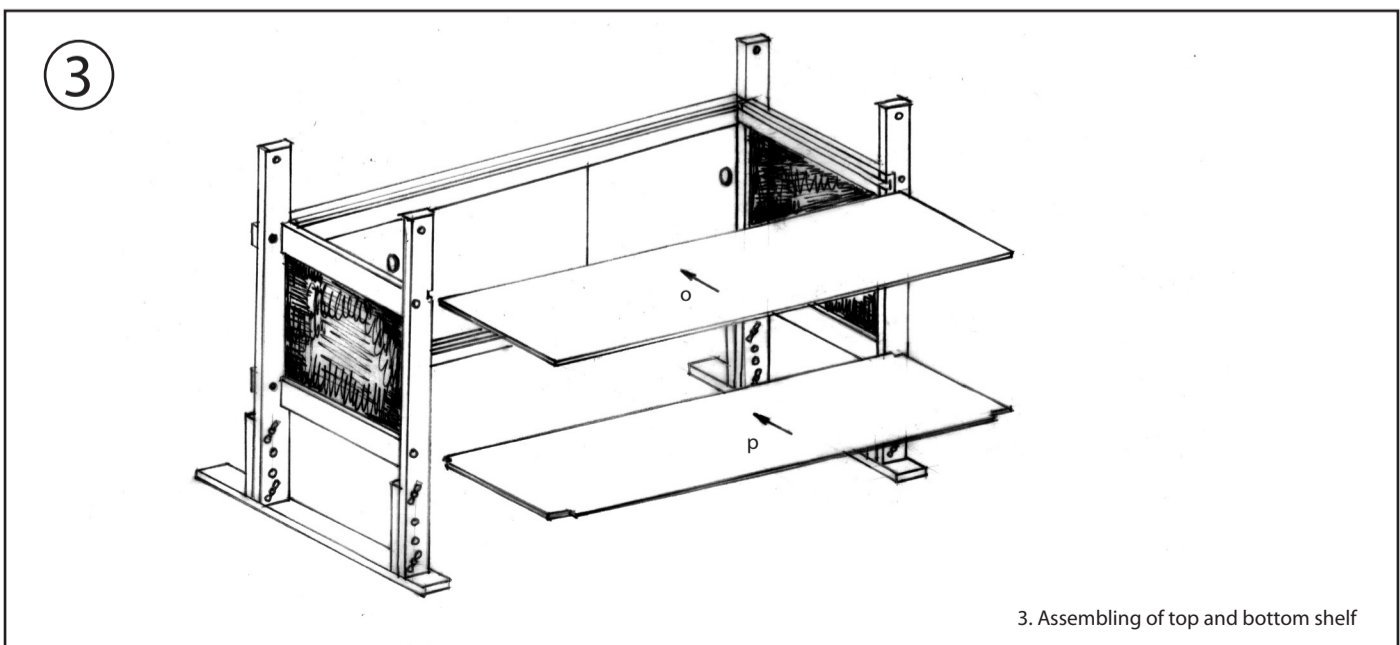
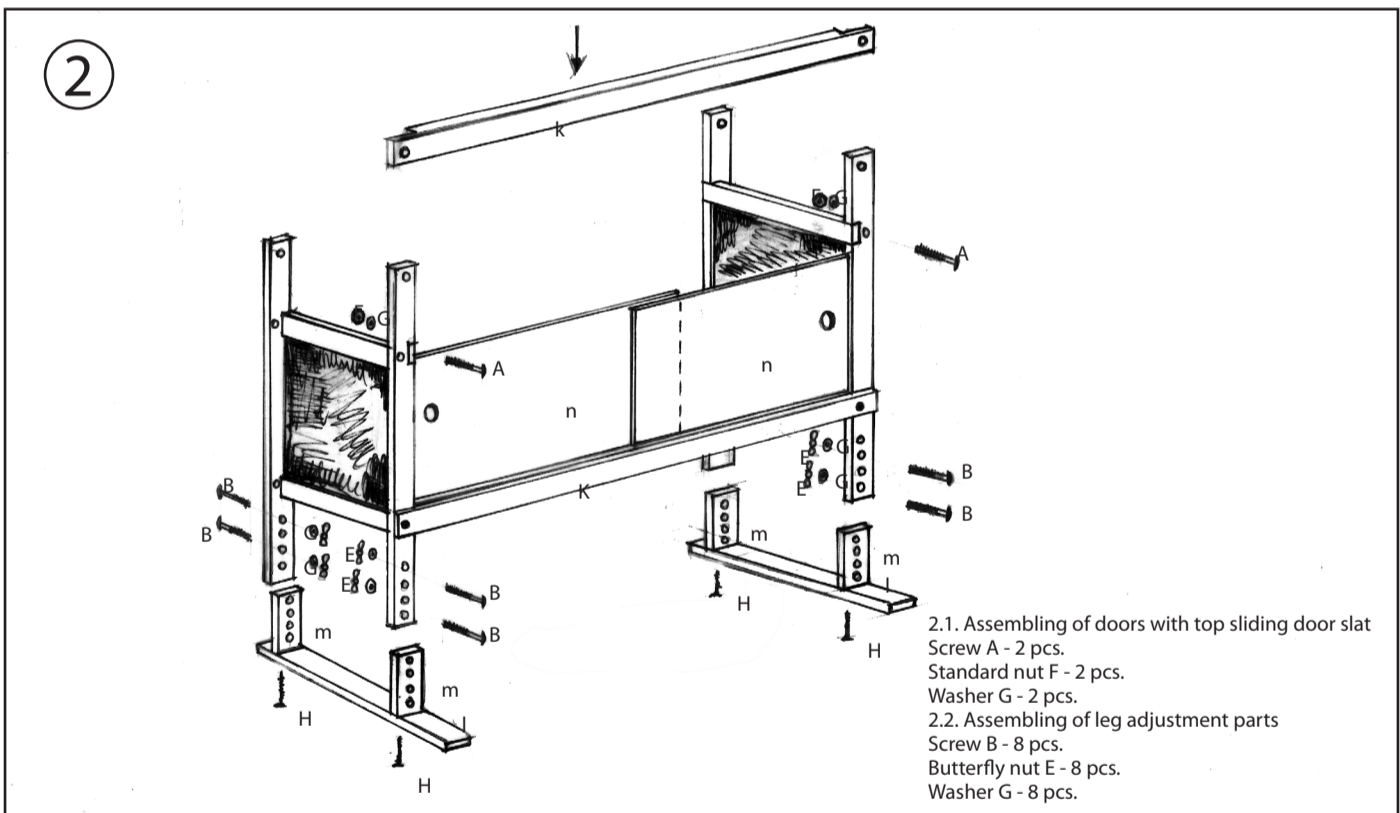
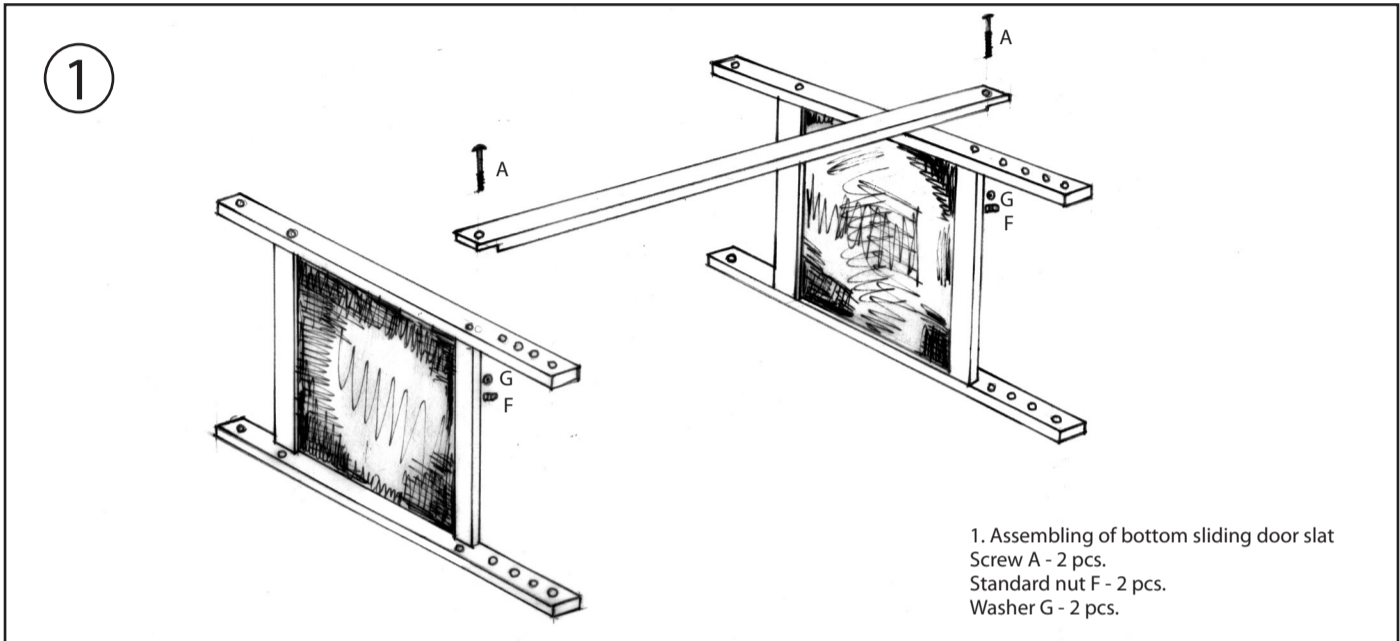
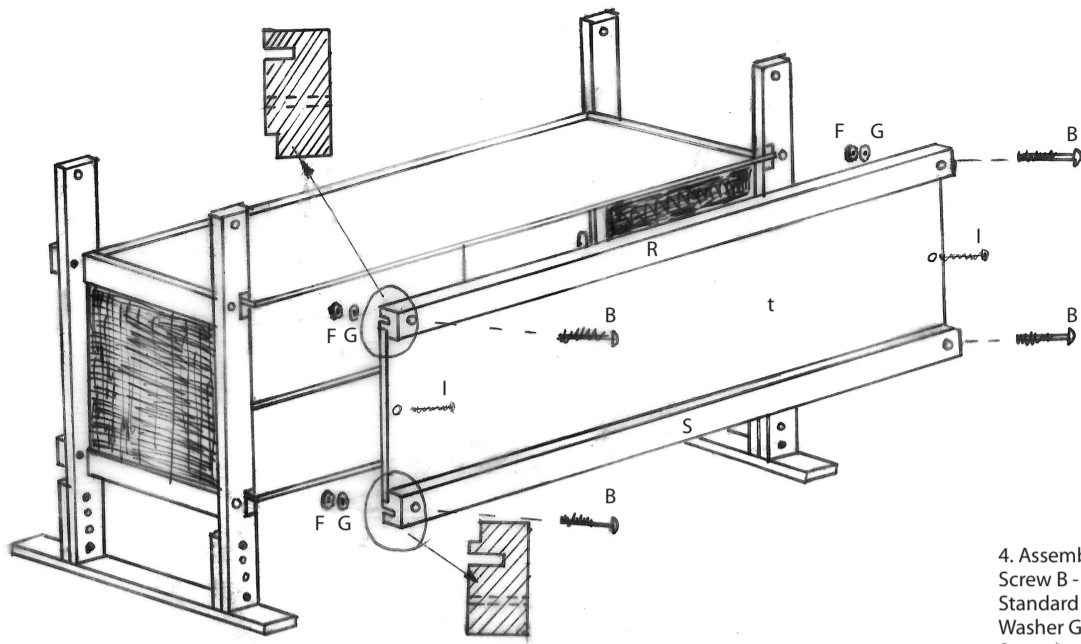

Table parts list:

- Workbench side – 2pcs – marked as j
- Top and bottom sliding door slat – 2pcs – marked as k
- Foot – 2pcs – marked as l
- Leg adjustment part – 4pcs – marked as m
- Sliding door – 2pcs – marked as n
- Top shelf – 1pcs – marked as o
- Bottom shelf – 1pcs – marked as p
- Back wall top slat – 1pcs – marked as r
- Back wall bottom slat – 1pcs – marked as s
- Back wall – 1pcs – marked as t
- Workbench plate – 1pcs – marked as u
- Front vice – 1pcs – marked as w
- Tightening pin – 2pcs – marked as x
- Tool holder wall – 1pcs – marked as y



4



4. Assembling of back wall  
 Screw B - 4 pcs.  
 Standard nut F - 4 pcs.  
 Washer G - 4 pcs.  
 Screw I - 2 pcs

5

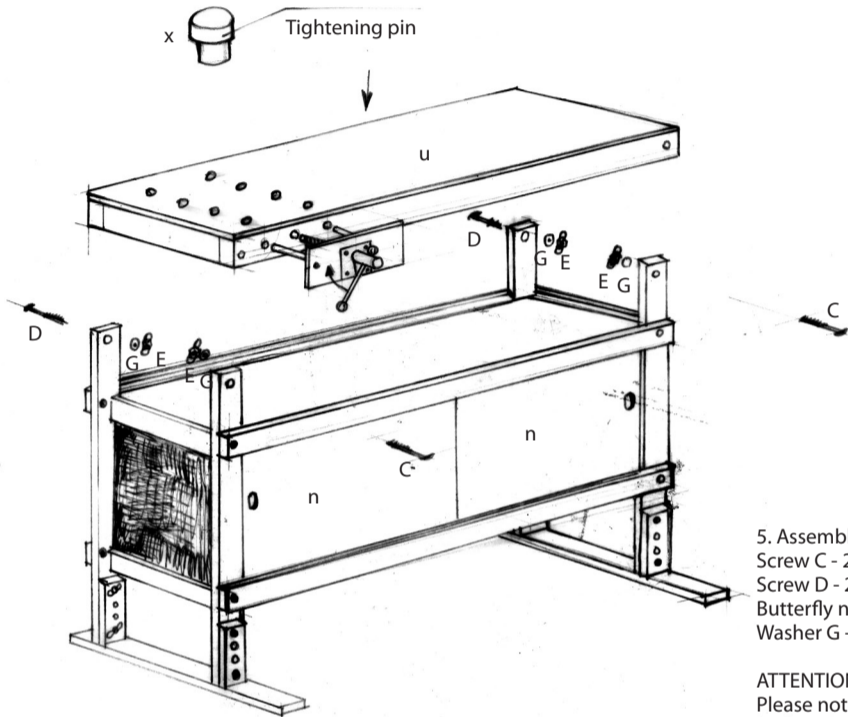

5. Assembling of workbench plate and vice  
 Screw C - 2 pcs.  
 Screw D - 2 pcs.  
 Butterfly nut E - 4 pcs.  
 Washer G - 4 pcs.

ATTENTION:  
 Please note screws "D" fix also tool holder wall

6

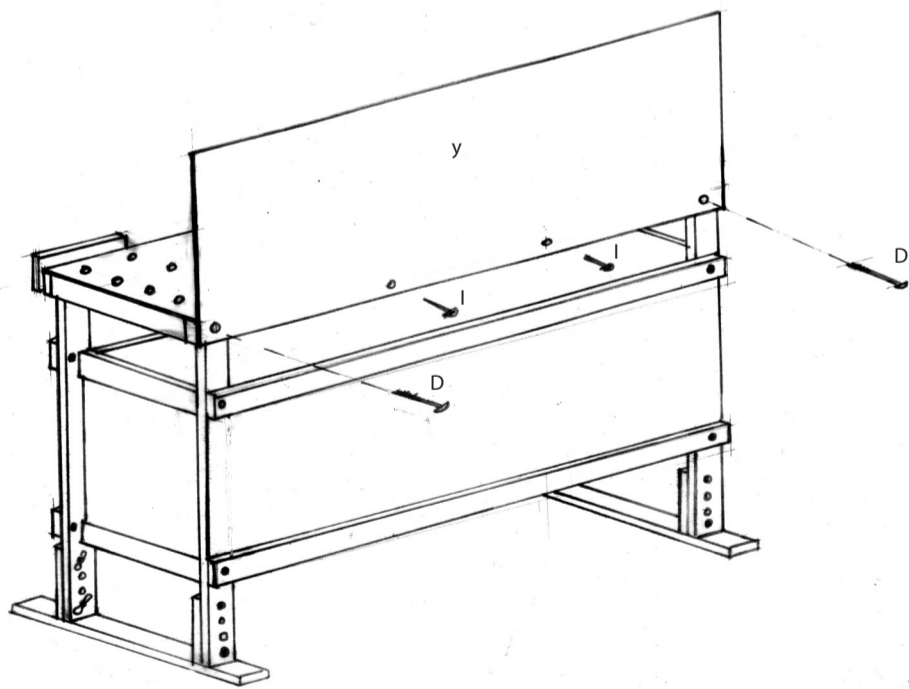

6. Assembling of tool holder wall  
 Screw H - 2 pcs



Krakpol 30668 Krakow,  
 ul. Polonijna 1, Poland  
 www.krakpol.com



MADE IN POLAND